

MASTER

3 HOLES Ø 30mm
MIDDLE HOLE IN CENTRE OF PLATE, TWO REMAINING
HOLES 70mm c/c FROM MIDDLE HOLE

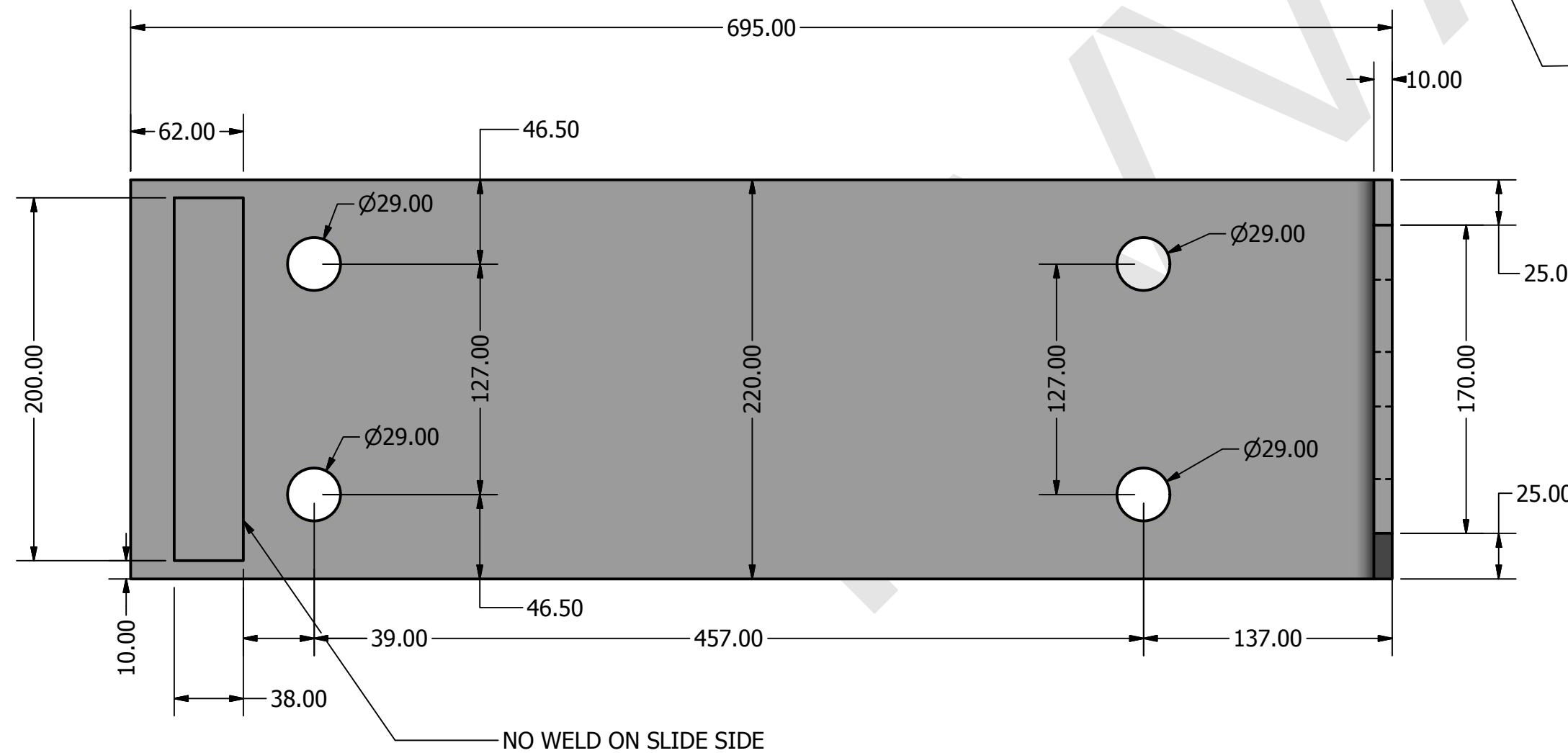
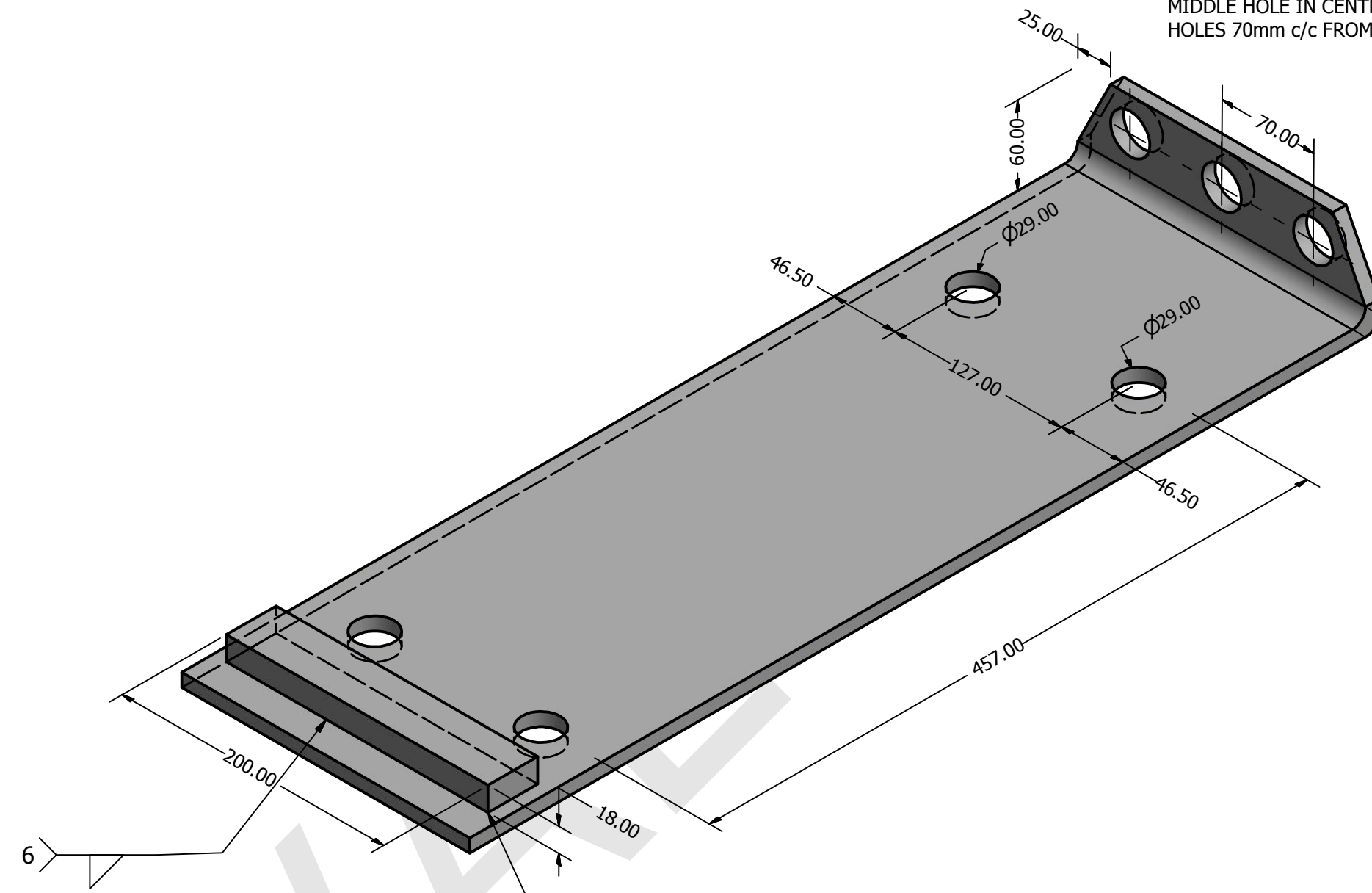

NOTE:

ALL MEASUREMENTS ARE IN MILLIMETRES
GAUGE STOP WELDED ON 3 SIDES ONLY, 6mm CONTINUOUS WELD
MATERIAL 10mm THICK MILD STEEL PLATE BS EN 10025 1990 FE 430A

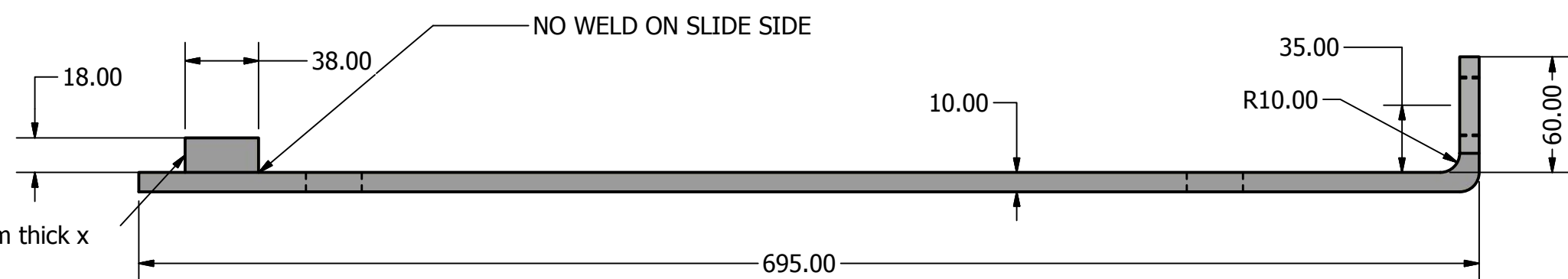

200mm x 38mm thick x 18mm

DRAWN	gdoogan	29/08/2013	RIVVAL	
CHECKED	MEM	29/08/2013		
MEM	QA		TITLE	
MFG			SOLE PLATE	
APPROVED	MM	29/08/2013	SIZE	DWG NO
			C	RP00580_11
			SCALE	REV
				00
			SHEET 1 OF 1	