

RIVVAL ONLINE

**GATOR PNEUMATIC MAGNETIC
DRILLING MACHINE**

Model No. **RP05520/10**

RIVVAL LTD,

Registered Office: RIVVAL Ltd.,
Oakdale,
Carrickasedge,
Carrickmacross,
Co. Monaghan,
Ireland.

Tel: +353 42 969 0882

Web: www.rivval.com

Email: sales@rivval.com

Company Number: 390186

VAT Number: 6410186G

CONTENTS OF THE MANUAL

- [1] Specification of machine
- [2] General procedure and safety measures
- [3] Operating instructions
- [4] Mounting of cutters
- [5] Remedies for hole making problems
- [6] Component parts of complete machine
- [7] Exploded view
- [8] Optional Extras
- [9] Maintenance
- [10] Pipe adaptor Kit
- [11] Warranty

	List of contents with drill unit	Check List
RD4329	Safety strap	YES/NO
RD4088	4mm A/F Tee handled hex key	YES/NO
RD4367	Pipe Adaptor Fixing Strap	YES/NO

[1] SPECIFICATION

Maximum hole cutting capacity in .2/.3C steel 52mm dia., 52mm deep.
Arbor bore 19.05mm dia. (3/4" dia.)

Motor Unit:		*Speed 630 rpm *Torque 4.0 da Nm (cont) *kW 2.4 (cont)
Magnet:	Manually operated Tractive force at 20°C(25mm min. plate thickness) The use on any material less than 25mm thick will progressively reduce the magnetic performance. If possible substitute material should be positioned under the magnet and work piece to equate to a suitable material thickness. If this is not possible an alternative secure method of restraining the machine MUST be used. Failure to do so may result in personal injury.	700kgs
Overall dimensions:	Height (max. extended) Height (min) Width (inc. capstan arms) Overall length (inc. guard and magnet handle)	550mm 470mm 180mm 315mm
Nett weight:		23kgs
Hydraulic supply required:	Inlet Pressure Oil Flow (L/min)	140 Bar (2050 psi) 20 (cont) 25 (int)
Sound pressure level (Ear protectors must be worn). Note: The figures quoted are emission levels and are not necessarily safe working levels. Whilst there is a correlation between the emission and exposure levels, this cannot be used reliably to determine whether or not further precautions are required. Factors that influence the actual level of exposure of the workforce include characteristics of the work room, the other sources of noise, etc. i.e. the number of machines and other adjacent processes. Also the permissible exposure level can vary from country to country. This information, however, will enable the user of the machine to make a better evaluation of the hazard and risk.		78 dB(A)

3/8" B.S.P. Male Connection Point

- Only when using a 100% hydraulic oil medium.

The motor should be purged with light lubricating oil after use.

NB: ANY MODIFICATIONS TO THIS MACHINE WILL INVALIDATE THE GUARANTEE

[2] SAFETY PROCEDURES

READ BEFORE USING THE MACHINE

Always secure the machine with the safety strap RD4329 before starting to operate - for the user's protection in case the magnetic base breaks loose whilst in use. Failure to do so may result in personal injury.

Always wear approved eye and ear protection when the equipment is in operation. Failure to do so may result in personal injury.

Disconnect from hydraulic supply source when changing cutters or working on the machine. Ensure that the hydraulic supply is connected after positioning the machine.

Never pick the machine up by the cutter as this is sharp and may injure you.

Always ensure cutter retaining screws are secure – they can sometimes vibrate loose during use.

Regularly clear the work area and machine of swarf and dirt, paying particular attention to the underside of the magnet base.

With a gloved hand, and after switching off, remove any swarf, which might have gathered around the cutter and arbor before proceeding with the next hole.

Before operating the machine, remove tie, rings, watches and any loose adornments, which might entangle with the rotating machinery. Ensure long hair is tied back.

Ensure that the magnet is fully activated before attempting to cut a hole.

Should the cutter become 'fast' in the work piece, switch off the motor immediately to prevent personal injury. Disconnect from the pneumatic supply and turn arbor to and fro. **Do not attempt to free the cutter by switching the motor on and off.**

If the machine is accidentally dropped, always thoroughly examine the machine for signs of damage and check that it functions correctly before trying to drill a hole.

Regularly inspect the machine and check that all nuts and screws are tight.

Cutting tools may shatter **always** extended the guard over the cutter during the drilling operation. Failure to do so may result in personal injury. When moving the machine ensure the guard is over the cutter failure to do so may cause injury.

On completion of the cut, a slug will be ejected. **DO NOT** operate the machine if the ejected slug may cause injury.

Ensure an adequate supply of coolant is supplied to the cutter during the cutting cycle.

Manual handling

When moving the machine always ensure that you use the carry handle on the machine failure to do so may cause damage to the machine.

Caution this machine is heavy and may require help manoeuvring especially when working overhead.

[3] OPERATING INSTRUCTIONS

Before connecting the hydraulic supply ensure the motor switch is in the **OFF** position.

Locate the machine in the required position for cutting the hole and activate the magnet by means of the ratchet handle (clockwise viewed from rear). Ensure that magnet rod is fully screwed home.

Keep the inside of the cutter clear of swarf - it restricts the operating depth of the cutter.

Apply the cutting fluid to the reservoir via the inducement slots in the arbor. It is then «metered» out by the pilot and is applied directly to the cutting edge. (Alternatively, fluid can be applied directly on to the work piece making certain that it floods into the groove formed by the cutter.)

Depress the pilot to ensure cutting fluid is being correctly metered.

Start the motor by turning the rotary valve to **ON** position

Apply light pressure when commencing to cut a hole until the cutter is introduced into the work surface. Pressure can then be increased sufficiently to load the motor. Excessive pressure is undesirable when using the *Rotabroach hydraulic* machine, it does not increase the speed of penetration and may cause the motor to stall. The motor will restart when the excessive pressure is released.

Always ensure that the slug has been ejected from the previous hole before commencing to cut the next.

If the slug sticks in the cutter, move the machine to a flat surface, switch on the magnet and gently bring the cutter down to make contact with the surface. This will usually straighten a cocked slug and allow it to eject normally.

Apply a small amount of light oil lubricant regularly to slide and arbor support bearing. Cutter breakage is usually caused by insecure anchorage, a loosely fitting slide or a worn bearing in the arbor support.

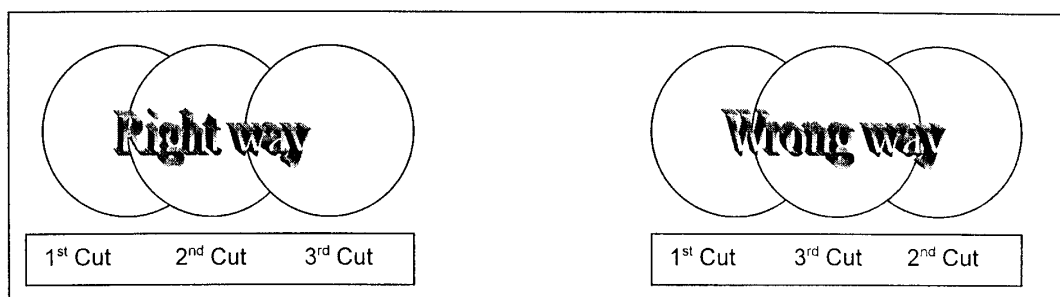

If the slug sticks in the cutter, move the machine to a flat surface, switch on the magnet and gently bring the cutter down to make contact with the surface. This will usually straighten a cocked slug and allow it to eject normally.

Apply a small amount of light oil lubricant regularly to slide and arbor support bearing. Cutter breakage is usually caused by insecure anchorage, a loosely fitting slide or a worn bearing in the arbor support. (Refer to routine maintenance instructions.)

[4] MOUNTING OF CUTTERS

The following procedure is to be used when mounting cutters.

ALWAYS DISCONNECT MACHINE FROM HYDRAULIC SUPPLY

Lay the machine on its side with feed handles uppermost, ensuring arbor is wound down to its lowest point to enable access to socket screws RD4066. Take the appropriate pilot and place through hole in shank of cutter. Insert shank of cutter into arbor ensuring alignment of two drive flats with socket screws RD4066. Tighten both screws securely using hexagon key RD4088.

[5] REMEDIES FOR HOLE MAKING PROBLEMS

Problem	Cause	Remedy
Magnetic base won't hold effectively	Material being cut may be too thin for efficient holding	Attach an additional piece of metal under work piece where magnet will be located, or mechanically clamp magnetic base to work piece
	Swarf or dirt under magnet	Clean magnet
	Irregularity on contact between magnet and work piece	Use extreme care, file only imperfections flush on to surface
Hole not cut at intended centre of cut	Magnetic base is not holding effectively	See causes and remedies above
	Worn arbor bushing and/or ejector collar	Replace! Only a few thousandths wear permissible. New arbor bushing is needed
	Too much feed pressure at start of cut	Light pressure until a groove is cut. The groove then serves as a stabilizer
	Cutter is dull, worn, chipped or incorrectly sharpened	Replace or re-sharpen. Sharpening service is available
	Worn or bent pilot, worn pilot hole	Replace part or parts
Poor hole quality, cutter not cutting, motor stops	Loose bolts on motor bushing support bracket, main casting or loose gib adjusting set screws	Adjust where necessary
	Incorrectly re-sharpened, worn or chipped cutter	Re-sharpen or replace
	Coming down on swarf lying on surface of work piece	Take care not to start a cut on swarf
	Insufficient air pressure/volume	Check air supply
	Gibs out of adjustment or lack of lubrication	Adjust set screws
Swarf accumulated (packed) inside cutter	Clear cutter	

Excessive cutter breakage	Steel swarf or dirt under cutter	Remove cutter, clean part thoroughly and replace
	Incorrectly re-sharpened or worn cutter	Always have a new cutter on hand to refer to for correct tooth geometry, along with instruction sheet
	Cutter skipping	See cause and remedy above
	Slideway needs adjustment	Adjust gibs
	Cutter not attached tightly to arbor	Retighten
	Insufficient use of cutting oil or unsuitable type of oil	Inject oil of light viscosity into the slot in the arbor and confirm oil is being metered into cutter when pilot is depressed. Check pilot groove and arbor internally for dirt or apply oil externally.
Excessive cutter wear	See cause and remedy above	
	Incorrectly re-sharpened cutter	Refer to instructions and a new cutter for proper tooth geometry
	Insufficient or spasmodic cutting pressure	Use sufficient steady pressure to slow the drill down. This will result in optimum cutting speed and chip load
Motor will not start	Insufficient air pressure/volume	Check air supply, spindle free to rotate

[6] PARTS LIST - RD140

<i>Item</i>	<i>Component</i>	<i>Part No</i>	<i>Item</i>	<i>Component</i>	<i>Part No</i>
1	Rack	RD3350	30	Guard Bracket	RD33000
2	Fixed Gib Strip	RD3317	31	Spring Plunger	RD4346
3	Adjustable Gib Strip	RD3316	32	Button	RA354
4	Gib Support Strip	RD3310	33	Spring	RA355
5	Spirol Pin	RA353	34	Circlip	RD4056
6	Thrust Washer	RA401	35	M8 Socket Screw	RD4066
7	Nylon Bearing	RD350	36	External Circlip	RD4320
8	Slide	RD3381	37	Motor Control Module Includes items 64 and 65	RD2365
9	Arbor Sleeve	RD3396	38	Arbor adaptor	RD33024
10	Bearing Bracket	RD3389	39	Arbor	RD33021
11	M5 Shakeproof Washer	RD4092	40	Motor Bracket	RD3395
12	M6 Shakeproof Washer	RD4096	41	M8 Socket Screw dog point	RD43135
13	M5 Socket Head Screw	RD4325	42	O ring	RD43136
14	M6 Stud	RD4340	43	Capstan Pinion Shaft	RD33088
15	M4 Shakeproof Washer	RD4069	44	Capstan Arm	RD33089
16	M4 Panhead screw	RD4077	45	Plastic Knob	RD43091
17	M8 Washer	RD4078	46	M3 Socket Head Screw	RD43130
18	M8 Shakeproof Washer	RD4079	47	M6 Socket Head Cap Screw	RD43128
19	M6 Nut	RD4087	48	M8 Socket Head Set Screw	RD43127
20	M6 Washer	RD4095	49	M6 Socket Head Screw	RD43126
21	Nyliner Bearing	RD4313	50	M5 x 16 Countersink Socket Screw	RD43131
22	M6 Spring Washer	RD4207	51	Magnet (includes Pole Piece Set) and items 66/67/68 & 77	RD43100
23	M6 Socket Screw	RD4312	52	Pinion Shaft Sleeve	RD33090
24	Tension Pin	RD4102	53	Housing	RD3380
25	Name Plate	RD43010	54	Key	RD3009
26	Information Plate	RD4362	55	Ratchet Handle	RD43049
27	Cover Plate	RD33017	56	M6 Socket Head Screw	RD43126
28	Identity Plate	RD33027	57	M6 Washer	RD33030
29	Guard	RD3397			

[7] EXPLODED VIEW – RD140

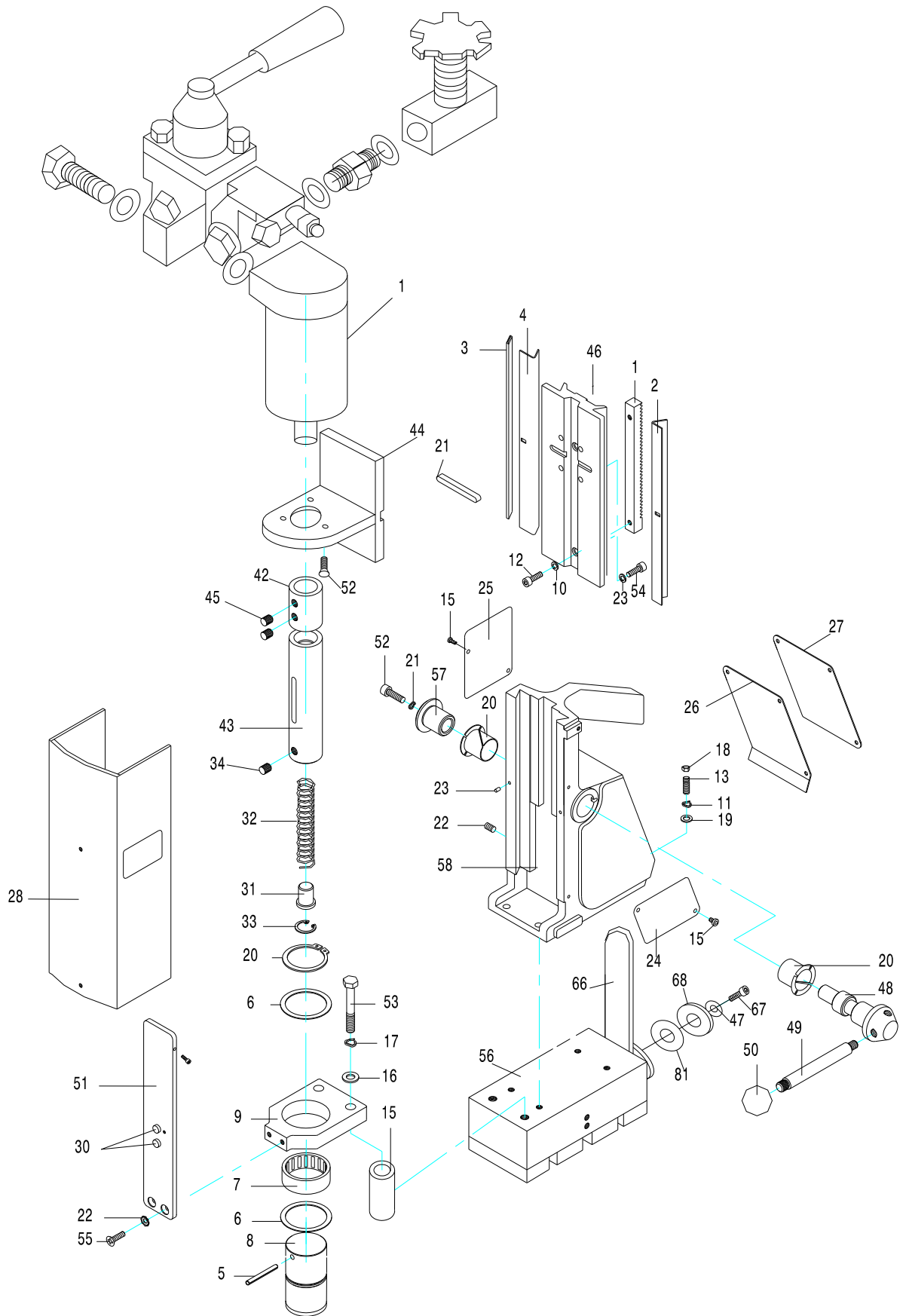

[8] OPTIONAL EXTRAS

ROTABROACH CUTTING FLUID

ROTABROACH CUTTING FLUID has been formulated to give maximum life to your ROTABROACH CUTTERS

RD208

Available in three sizes:

RD208 1 litre

RD229 5 litres

RD220 25 litres

CHUCK

RD4189 1/2" capacity chuck + key

RD4190 Chuck key

RD324 Chuck spacer

This chuck can only be fitted to drill units having a 5/8"-16 UNS output spindle nose.

Remove the bearing bracket, sleeve and arbor or any other fittings. Place spacer RD324 onto the spindle, screw the chuck tightly against the spacer and lock into position.

When refitting the arbor assembly, care must be taken to ensure correct alignment to the vertical axis and that it is running concentric.

[9] Tips for keeping your machine in correct working order.

In order to 'get the best life' out of your Rotabroach machine always keep in good working order. A well maintained machine is a happy machine.

A number of items must always be checked on Rotabroach machines.

Always before starting any job make sure the machine is in good working order and that there are no damaged or loose parts. Any loose parts must be tightened.

Before proceeding with any maintenance work be certain that the HYDRAULIC supply is disconnected

Description	Every operation	1 week	1 Month
Visual check of machine for damage	X		
Operation of machine	X		
Check magnetic base	X		
Check alignment of the machine			X

Visually check the machine for damage.

Machine must be checked before operation for any signs of damage that will affect the operation of the machine. Particular notice must be taken of the mains cable, if the machine appears to be damaged it should not be used failure to do so may cause injury or death.

Check operation of the machine.

The machines operation must be checked to ensure that all components are working correctly.

Magnetic base – before every operation the magnetic base should be checked to make sure that the base is flat and there is no damage present. An uneven magnet base will cause the magnet not to hold as efficiently and may cause injury to the operator.

Adjustment of slide and bearing bracket Alignment.

An essential requirement of the machine is that the slide can move in a smooth and controlled manner, free of lateral movement and vibration.

This situation can be maintained by periodic adjustment of the slide and is accomplished in the following manner:

1. Place the machine in an upright position and, by means of the capstan, raise the slide to its highest position. Clean the brass gib strips and apply a small amount of light machine oil to the wear surfaces.
2. Now lower the slide back to its lowest position. Bring the slide into the centre of the dovetail slide housing and loosen screws thus allowing free movement of the arbor support bracket.
3. Commencing with the middle screws, gently feed in all the screws until slight resistance is encountered.
4. Operate the slide up and down a few times to test the movement and make any further necessary adjustments. Try to ensure that all the screws are exerting a uniform pressure on the slide from top to bottom. A perfectly adjusted slide will operate freely up and down without any sideways movement.
5. Now raise the slide to its highest position. Slightly undo the arbor bearing bracket and, using fingers only, tighten the screws.
6. Place the machine on a steel plate, connect to supply and switch on magnet. Start up the motor. If the arbor is incorrectly aligned, the arbor support bracket will be seen to oscillate. Make any necessary further adjustments to the bracket to ensure correct alignment of the spindle and finally tighten the screws using a spanner. Lastly tighten the arbor bearing bracket.

[10] PIPE ADAPTOR KIT RD2311

FITTING INSTRUCTIONS

- Dependent upon the size of the pipe to be cut (see illustrations) attach adjustable angle plates RD3328 with cap screws RD4325 and washers RD4205 (4 off each) to the magnet sides. Do not tighten.
- Locate the machine on the centreline pipe taking care that the magnet is in line with the longitudinal axis of the pipe.
- Switch on the magnet and move the sliding plates down to the outside diameter of the pipe. Tighten the screws on both sides by hand then check once again that the full length of the moving plates is touching the pipe at the front and back, fasten the plate securely. Feed the safety strap through the lugs at the front of the housing, around the pipe and pull tight.
- When cutting the hole DO NOT use excessive pressure but rather let the cutter ease into the cutting surface.

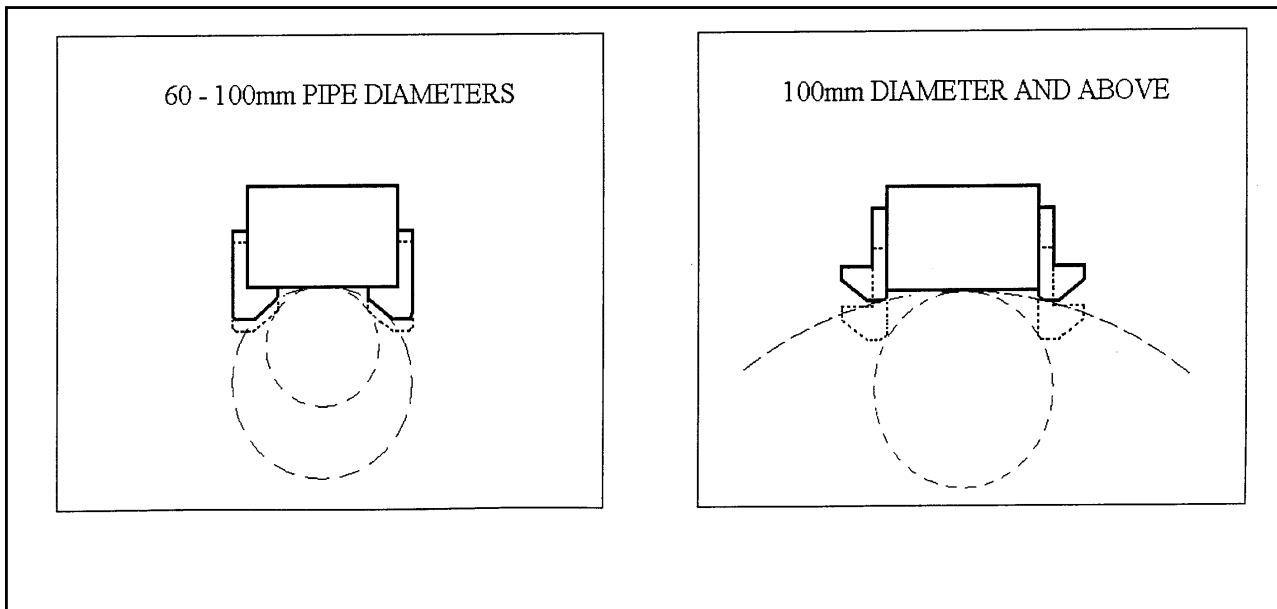

NOTES:

Rotabroach[®]

WARRANTY STATEMENT

Rotabroach® warrants its machines to be free from faulty materials, or workmanship under normal use for a period of 6 months from initial date of purchase and 90 days for all other parts (excluding cutters), provided that the warranty registration card (or online registration) has been completed and returned to Rotabroach®, or its designated distributor within a period of (30) days from the purchase date, failure to do so will void the warranty. If the stated is adhered to Rotabroach® will repair or replace (at its option) without charge any faulty items returned.

This Warranty does not cover:

1. Components that are subject to natural wear and tear caused by the use in accordance with the operators instructions
2. Defects in the tool caused by non-compliance with the operating instructions, improper use, abnormal environment conditions, inappropriate operating conditions overload or insufficient servicing or maintenance.
3. Defects caused by using accessories, components or spare parts other than original Rotabroach® parts.
4. Tools to which changes or additions have been made.
5. Electrical components are subject to manufacturer's warranty.

Your online registration can be submitted on www.rotabroach.co.uk

The warranty claim must be lodged within the warranty period. This requires the submission or sending of the **complete** tool in question with the original sales receipt which must indicate the purchase date of the product. A complaint form must also be submitted prior to the return.

This can be found online at www.rotabroach.co.uk Failure to complete this form will result in the delay of your claim.

All goods returned defective must be returned pre-paid to Rotabroach®, in no event shall Rotabroach® be liable for subsequent direct, or indirect loss or damage.

THIS WARRANTY IS IN LIEU OF ANY OTHER WARRANTY, (EXPRESSED OR IMPLIED) INCLUDING ANY WARRANTY OF MECHANICALITY OR FITNESS FOR A PARTICULAR PURPOSE. ROTABROACH® RESERVE THE RIGHT TO MAKE IMPROVEMENTS AND MODIFICATIONS TO DESIGN WITHOUT PRIOR NOTICE